

SFP-OT-SC01-EP-20-1.25G/

Tx1490nm/Rx1310/20km

1. Features

- SFP with SC/PC Connector Transceiver
- 1490 nm DFB Tx
- 1310 nm APD Rx
- Digital diagnostics SFF-8472 Compliant
- 1250 Mbps continuous mode Transmission
- 1250 Mbps Burst mode receiver Data Rate
- Provide fast RSSI function
- Operation case temperature: 0~70°C
- Complies with RoHS directive (2002/95/EC)

2. Application

- GEAPON OLT IEEE802.3ah 1000BASE-PX20+
- FTTx

3. Function Diagram

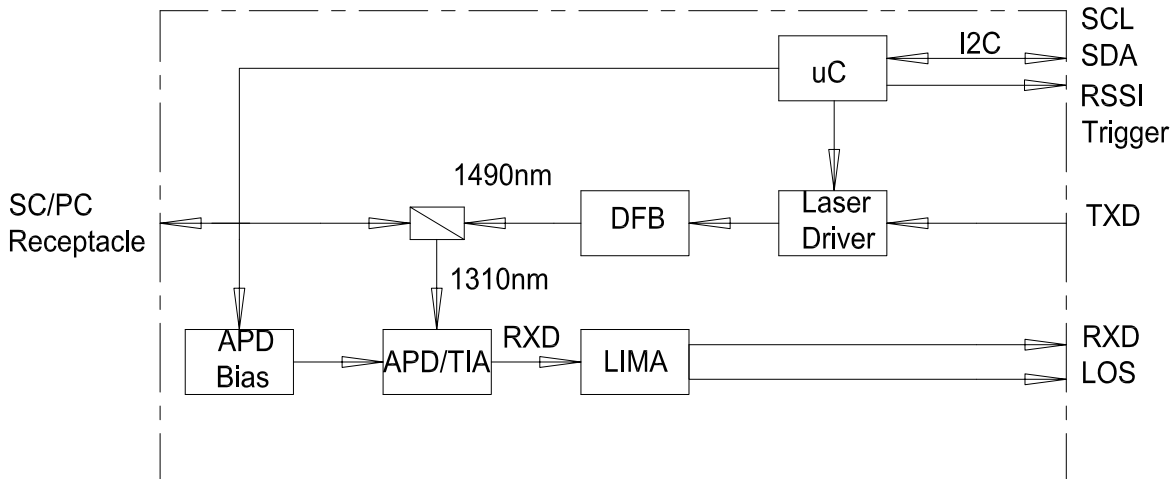

4. Recommended Operating Conditions

Parameter	Symbol	Min.	Max.	Unit
Storage Temperature	TSTG	-40	85	°C
Operating Case Temperature	TC	0	70	°C
Power Supply Voltage	VCC	3.1	3.5	V
Total Power Supply Current	ICC	-	350	mA

5. Transmitter Characteristics

Parameter	Symbol	Min.	Typ.	Max.	Units	Notes
Optical Transmitter Power	P0	2.5	-	7	dBm	1
Optical Transmitter Power off	POFF	-	-	-39	dBm	
Output Center Wavelength	λ	1480	-	1500	nm	
Output Spectrum Width	$\Delta\lambda$	-	-	1.0	nm	
Side Mode Suppression Ratio	SMSR	30	-	-	dB	
Extinction Ratio	ER	9	-	-	dB	
Optical Rise Time	-	-	-	260	ps	
Optical Fall Time	-	-	-	260	ps	
Optical Eye Diagram	Compliant with IEEE Std 802.3ahTM-2004					
Tolerance to Tx Back Reflection	-	-15	-	-	dB	
Data Rate	-	-	1.25	-	Gb/s	
Single Ended Data Input Voltage Swing	VPP	200	-	1200	mV	
Differential Input Impedance	ZIN	80	100	120	ohm	
Tx_fault Output Voltage- High	VOH	2.4	-	-	V	
Tx_fault Output Voltage- Low	VOL	-	-	0.4	V	
Tx_Dis Input Voltage- High	VIH	2.0	-	-	V	
Tx_Dis Input Voltage- Low	VIL	-	-	0.8	V	

Note 1: 1.25Gbps continuous-mode , PRBS2⁷-1.

6. Receiver Characteristics

Parameter	Symbol	Min.	Typ.	Max.	Units	Notes
Wavelength of Operation	-	1260	-	1360	nm	-
Data Rate	-	-	1.25	-	Gb/s	-
Sensitivity	Sen	-	-	-30	dBm	1
Saturation Optical Power	Sat	-8	-	-	dBm	1
LOS Assert Level	LOSA	-45	-	-	dBm	2
LOS Deassert Level	LOSD	-	-	-31	dBm	2
Reflectance of equipment	-	-	-	-20	dB	
Receiver Burst-mode Dynamic Range	-	15	-	-	dB	3
Data Output Voltage - High	VOH	V _{ccR} -1.05	-	V _{ccR} -0.85	V	-
Data Output Voltage - Low	VOL	V _{ccR} -1.84	-	V _{ccR} -1.60	V	-
RSSI accuracy	-	-3	-	3	dB	4
LOS Output Voltage- High	VLOSH	2	-	-	V	
LOS Output Voltage- Low	VLOSL	-	-	0.8	V	
LOS Assert Time	TA	-	-	500	ns	
LOS Deassert Time	TD	-	-	500	ns	
RSSI Trigger-Low	-	0	-	0.8	V	
RSSI Trigger-High	-	2.0	-	V _{cc}	V	
RSSI Trigger Delay	T _D	975	1000	1025	ns	5
RSSI Trigger Width	T _w	10	-	-	us	
Optical Signal During Time	T _{ONU EN_DUR}	1000	-	-	ns	6

Note 1: Measured with 1310nm, 1.25Gbps PRBS⁷-1 Single burst packet optical input, ER=10dB, BER=1x10⁻¹⁰.

Note 2: Measured at continuous mode.

Note 3: Input optical power level difference of adjacent burst packets.

Note 4: Receiver optical power ranged from -8dBm to -30dBm, measured with 1310nm, 1.25Gbps PRBS⁷-1 burst-mode optical input, ER=10dB, 50%duty cycle.

Note 5: Refer to first bit of the preamble

Note 6: 400ns CDR time and 600ns Data During Time.

7. Burst Mode Receiver Dynamic Range

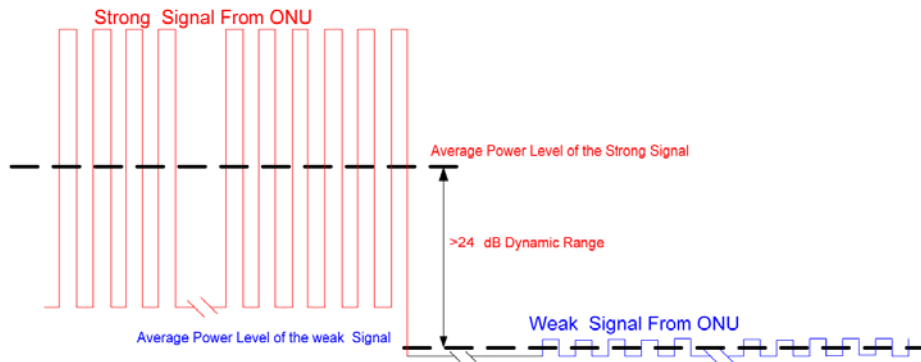

8. Timing Parameter Definitions in Burst Mode Sequence

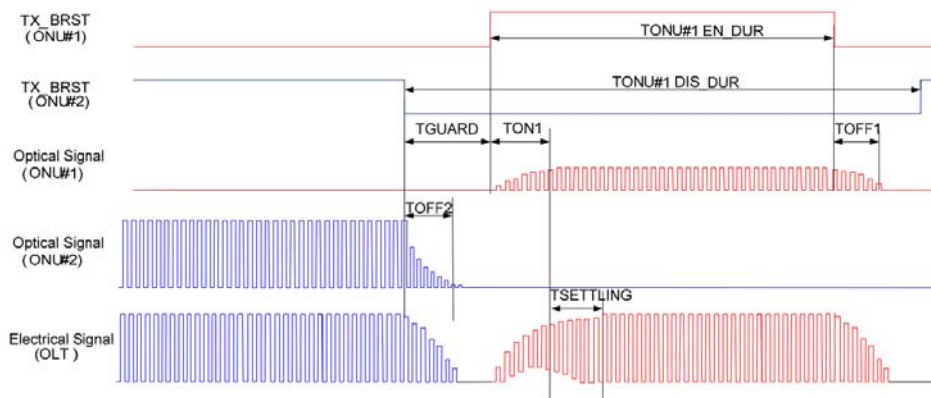

9. RSSI Timing Sequence

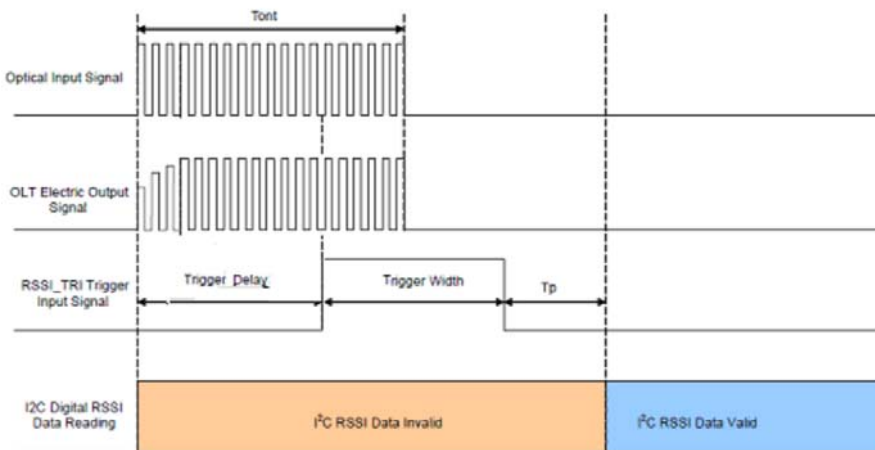

10. Digital Diagnostic Monitoring Accuracy

Parameter	Accuracy	Units	Notes
Transceiver Temperature	±3	°C	Temperature sensor
Power Supply Voltage	±3	%	Vcc=3.13~3.47V
TX Bias Current	±10	mA	-
TX Optical Power	±3	dB	Average Power
Rx Receiver Power	±3	dB	-

11. Pin Definitions

Pin#	Name	Function
1	VeeT	Transmitter Ground
2	TX_Fault	Transmitter Fault Indication, LVTTTL Output, Active High
3	TX_Disable	Transmitter Disable, LVTTTL Input. Optical output power is off when this PIN is high or left unconnected.
4	SDA	I2C Data
5	SCL	I2C Clock
6	MOD-DEF(0)	Internally grounded
7	RSSI_Trigger	RSSI Trigger Signal from Host, LVTTTL input, Active High.
8	LOS	Loss of Signal, LVTTTL Output, Active High.
9	VeeR	Receiver Ground
10	VeeR	Receiver Ground
11	VeeR	Receiver Ground
12	RD-	Inv. Received Data Out, LVPECL,DC coupled
13	RD+	Received Data Out, LVPECL,DC coupled
14	VeeR	Receiver Ground
15	VccR	Receiver Power
16	VccT	Transmitter Power
17	VeeT	Transmitter Ground
18	TD+	Transmit Data In, LVPECL or CML (AC coupled; internally 100 ohms differential termination)
19	TD-	Inv. Transmit Data In, LVPECL or CML (AC coupled; internally 100 ohms differential termination)
20	VeeT	Transmitter Ground

12. Outline Drawing

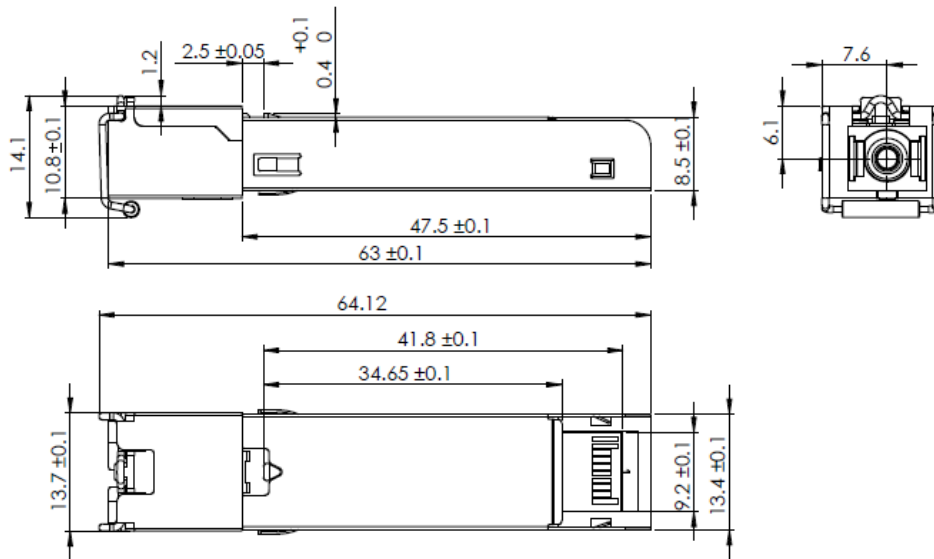

13. Recommended Application Circuit

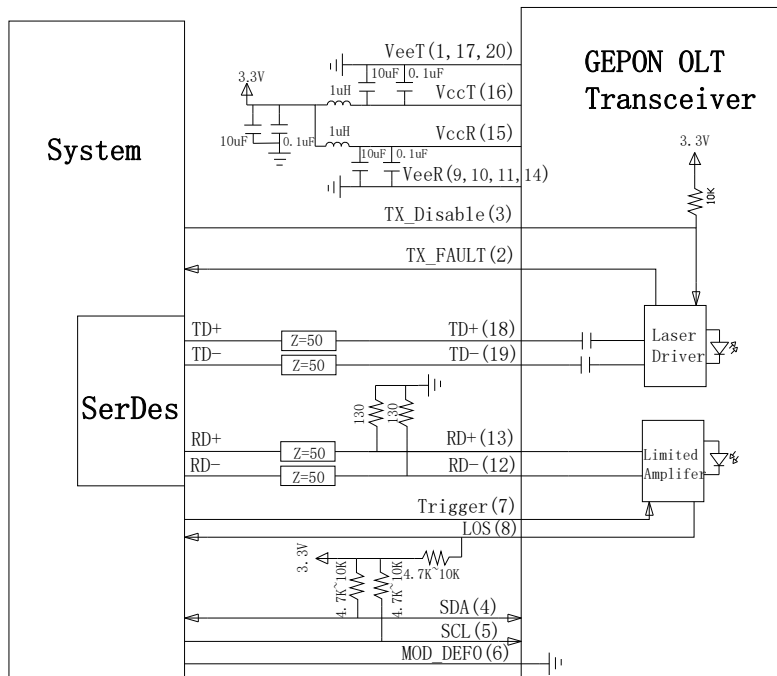

14. Ordering Information

Part Number	Product description	RoHS Compliant
SFP-OT-SC01-EP-20-1.25G/Tx1490nm/Rx1310/20km	GEPON OLT SFP/Tx1490/Rx1310/20km/Tx1.25G/Rx1.25G/ PX20+/0~70°C/SC Receptacle	RoHS-6